

Scalable DC to AC Inverter

FEATURES



Reliable, Scalable, Flexible and Compact.....

ONYX® inverters are the industry standard inverter for critical environments like the telecom and data center industry. The ONYX S5 uses high density circuitry to provide 1500 Watts of power into a slim 1U rack mountable enclosure.

Built for noise sensitive DC environments: DC noise filtering circuits on the ONYX S5 practically eliminates ripple current (<30 dBNC and less than 2mV psophometric), a by product of most inverters that can potentially damage even large DC battery banks.

The Ultimate in Scalability: The ONYX S5 can be paralleled for capacity or redundancy using the "plug and play" synchronization cables. No external circuitry is required. In excess of 20 units can be paralleled for capacity.

Single Phase / Three Phase / Split Phase: The S5 can be configured for single phase, split phase or three phase output. For three phase output, the S5 can be configured in groups of three inverters (either parallel or single module groups). Applications requiring split phase outputs (i.e. 208 V and 120 VAC out) are addressed using the split phase output converter module.

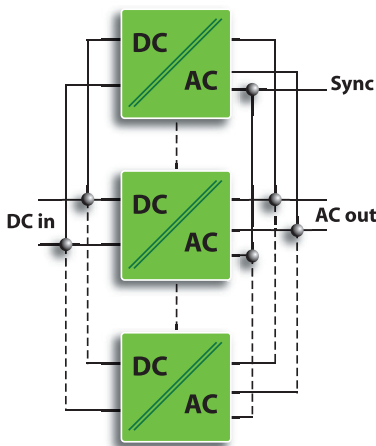

The ONYX S5 can be paralleled for capacity or redundancy without any paralleling gear. Simply connect the sync cables between modules.

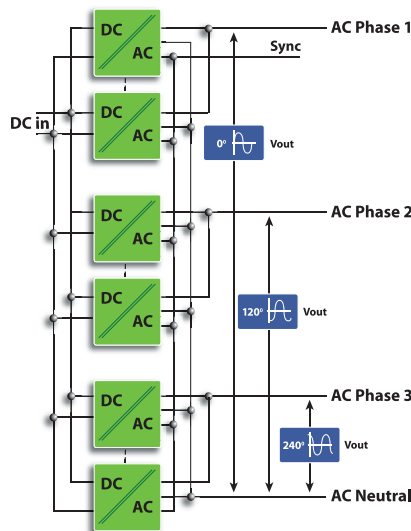

Three phase output is made possible by connecting inverters in groups of three either in parallel or single module clusters.

- ▶ N+1 parallelable operation for capacity or redundancy without additional hardware
- ▶ Ultra compact 1U module size
- ▶ Single or Three Phase output configurations
- ▶ Microprocessor controlled status and monitoring ensures precise operation of all inverter functions
- ▶ True sine wave output
- ▶ 24 or 48 VDC input options
- ▶ 120 or 240 VAC 50 / 60 Hz outputs
- ▶ Integrated static bypass switch option
- ▶ High efficiency (93%) making it ideal for alternative energy applications
- ▶ LCD and LED status display
- ▶ Serial or CANBUS communications
- ▶ Accommodates harsh environments in excess of 40°C
- ▶ DC noise filtering eliminates noise on DC bus (<2mV psophometric)
- ▶ On-line or off-line mode selectable
- ▶ Meets UL, cUL, and CE requirements



Scalable DC to AC Inverter

TECHNICAL SPECIFICATIONS

Electrical Characteristics

Input voltage	48 VDC (40-72 VDC) or 24 VDC (20-36 VDC)
Output voltage	115 VAC (100-120 VAC) or 230 VAC (200-240 VAC) - select 115 or 230 VAC model
Output power	1500 W
Output waveform	True sine wave
Frequency	50/60 Hz (47-63 Hz) - select 50 or 60 Hz model
Frequency (stability)	±0.02% maximum
Inverter technology	Pulse Width Modulation /High Frequency Switching
Dielectric strength	2,500 VAC minimum
Inrush current	<10 A
Operating modes	On-line (standard); Standby (selectable)
Efficiency	peak efficiency 93%
Output power factor	0.33 lagging or leading
Total Harmonic Distortion	2% maximum for linear loads /<3% for non-linear loads
DC noise feedback	< 30 dBrc
Transient response	<3% voltage change on instantaneous 0 to 100% load change
Transfer time (with static switch)	< 2 msec
Overload capacity	up to 125% continuous; 125% to 150% - 1800 cycles, 150% to 220% - 24 cycles, 220% to 300% - 4 cycles
Load Voltage Regulation	+3%/-1%
Communications	RS-485 or CANBUS communications interface and photo alarm relay
Display	2 x 20 LCD display (optional) with LED status bar
Input overvoltage protection	48 VDC models: 74 V 24 VDC Models: 37 V
Input Undervoltage protection	48 VDC models: 36 V 24 VDC Models: 18 V
Overload	230 VAC models: 1800 VA 115 VAC Models: 1650 VA
Surge capacity	230 VAC models: 2300 VA for 200 ms 115 VAC Models: 1750 VA for 200 ms
Electronic overcurrent protection	230 VAC Models: 1 A to 8 A (selectable) 115 VAC Models: 2 A to 15 A (selectable)
AC circuit breaker	230 VAC Models: 10 A 115 VAC Models: 15 A
Electronic short-circuit protection:	230 VAC Models: 30 A 115 VAC Models: 60 A
Protection mode	Programmable for "latch" or "auto restart" after incident
Isolation:	PRI-SEC: 3000 Vrms PRI-GND: 1000 Vrms SEC-GND: 1500 Vrms Signal-GND: 0 Vrms

Environmental Characteristics

Temperature	Operating: -25° C to + 55° C Storage: -40° C to + 85° C
Operating altitude	up to 15,000 feet above sea level without derating

Agency Certifications

Listings	UL, CE,
----------	---------

Model Description

Model	Input Current Max A. DC	Input Overcurrent Protection	Dimensions (H"xW"xD")	Weight (lbs/ kg)	Model Number
48 VDC (select 50 or 60 Hz / 120 / 230 VAC)	48 A	70 A	1.7" x 19.0" x 15.0"	12.5/5.6	S548
24 VDC (select 50 or 60 Hz / 120 / 230 VAC)	100 A	140 A	1.7" x 19.0" x 15.0"	12.5/5.6	S524

Options

- ▶ Integrated Static Transfer Switch
- ▶ Paralleling Sync Cable
- ▶ Split Phase Output
- ▶ Three Phase Output Kit



TPZ53 100-3/05

